

MC3425

Power Supply Supervisory/ Over and Undervoltage Protection Circuit

The MC3425 is a power supply supervisory circuit containing all the necessary functions required to monitor over and undervoltage fault conditions. These integrated circuits contain dedicated over and undervoltage sensing channels with independently programmable time delays. The overvoltage channel has a high current Drive Output for use in conjunction with an external SCR Crowbar for shutdown. The undervoltage channel input comparator has hysteresis which is externally programmable, and an open-collector output for fault indication.

- Dedicated Over and Undervoltage Sensing
- Programmable Hysteresis of Undervoltage Comparator
- Internal 2.5 V Reference
- 300 mA Overvoltage Drive Output
- 30 mA Undervoltage Indicator Output
- Programmable Time Delays
- 4.5 V to 40 V Operation

MAXIMUM RATINGS

Rating	Symbol	Value	Unit
Power Supply Voltage	V_{CC}	40	Vdc
Comparator Input Voltage Range (Note 1)	V_{IR}	-0.3 to +40	Vdc
Drive Output Short Circuit Current	$I_{OS(DRV)}$	Internally Limited	mA
Indicator Output Voltage	V_{IND}	0 to 40	Vdc
Indicator Output Sink Current	I_{IND}	30	mA
Power Dissipation and Thermal Characteristics			
Maximum Power Dissipation @ $T_A = 70^\circ\text{C}$	P_D	1000	mW
Thermal Resistance, Junction-to-Air	$R_{\theta JA}$	80	$^\circ\text{C/W}$
Operating Junction Temperature	T_J	+150	$^\circ\text{C}$
Operating Ambient Temperature Range	T_A	0 to +70	$^\circ\text{C}$
Storage Temperature Range	T_{stg}	-55 to +150	$^\circ\text{C}$

NOTE: 1. The input signal voltage should not be allowed to go negative by more than 300 mV or positive by more than 40 V, independent of V_{CC} , without device destruction.

POWER SUPPLY SUPERVISORY/ OVER AND UNDERVOLTAGE PROTECTION CIRCUIT

SEMICONDUCTOR TECHNICAL DATA

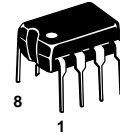

P1 SUFFIX
PLASTIC PACKAGE
CASE 626

PIN CONNECTIONS

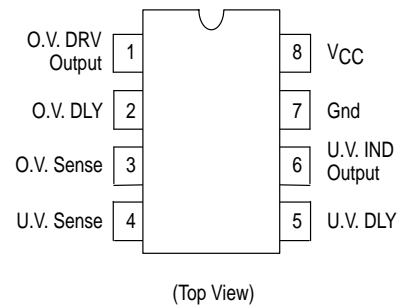

Simplified Application

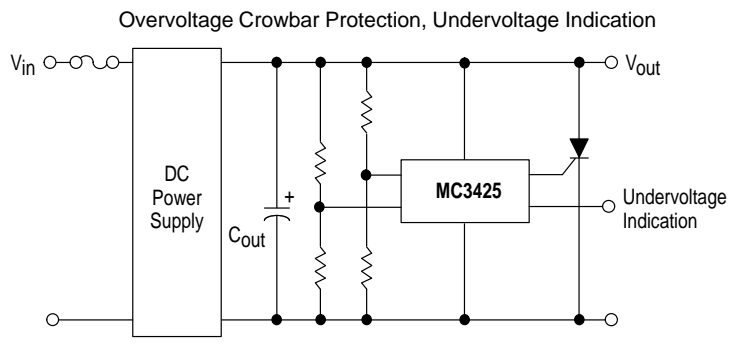

ORDERING INFORMATION

Device	Operating Temperature Range	Package
MC3425P1	$T_A = 0^\circ$ to $+70^\circ\text{C}$	Plastic DIP

MC3425

ELECTRICAL CHARACTERISTICS (4.5 V ≤ V_{CC} ≤ 40 V; T_A = T_{low} to T_{high} [Note 2], unless otherwise noted.)

Characteristics	Symbol	Min	Typ	Max	Unit
REFERENCE SECTION					
Sense Trip Voltage (Referenced Voltage) V _{CC} = 15 V T _A = 25°C T _{low} to T _{high} (Note 2)	V _{Sense}	2.4 2.33	2.5 2.5	2.6 2.63	Vdc
Line Regulation of V _{Sense} 4.5 V ≤ V _{CC} ≤ 40 V; T _J = 25°C	Reg _{line}	–	7.0	15	mV
Power Supply Voltage Operating Range	V _{CC}	4.5	–	40	Vdc
Power Supply Current V _{CC} = 40 V; T _A = 25°C; No Output Loads O.V. Sense (Pin 3) = 0 V; U.V. Sense (Pin 4) = V _{CC}	I _{CC(off)}	–	8.5	10	mA
O.V. Sense (Pin 3) = V _{CC} ; U.V. Sense (Pin 4) = 0 V	I _{CC(on)}	–	16.5	19	mA
INPUT SECTION					
Input Bias Current, O.V. and U.V. Sense	I _{IB}	–	1.0	2.0	μA
Hysteresis Activation Voltage, U.V. Sense V _{CC} = 15 V; T _A = 25°C; I _H = 10% I _H = 90%	V _{H(act)}	– –	0.6 0.8	– –	V
Hysteresis Current, U.V. Sense V _{CC} = 15 V; T _A = 25°C; U.V. Sense (Pin 4) = 2.5 V	I _H	9.0	12.5	16	μA
Delay Pin Voltage (I _{DLY} = 0 mA) Low State High State	V _{OL(DLY)} V _{OH(DLY)}	– V _{CC} –0.5	0.2 V _{CC} –0.15	0.5 –	V
Delay Pin Source Current V _{CC} = 15 V; V _{DLY} = 0 V	I _{DLY(source)}	140	200	260	μA
Delay Pin Sink Current V _{CC} = 15 V; V _{DLY} = 2.5 V	I _{DLY(sink)}	1.8	3.0	–	mA
OUTPUT SECTION					
Drive Output Peak Current (T _A = 25°C)	I _{DRV(peak)}	200	300	–	mA
Drive Output Voltage I _{DRV} = 100 mA; T _A = 25°C	V _{OH(DRV)}	V _{CC} –2.5	V _{CC} –2.0	–	V
Drive Output Leakage Current V _{DRV} = 0 V	I _{DRV(leak)}	–	15	200	nA
Drive Output Current Slew Rate (T _A = 25°C)	di/dt	–	2.0	–	A/μs
Drive Output V _{CC} Transient Rejection V _{CC} = 0 V to 15 V at dV/dt = 200 V/μs; O.V. Sense (Pin 3) = 0 V; T _A = 25°C	I _{DRV(trans)}	–	1.0	–	mA (Peak)
Indicator Output Saturation Voltage I _{IND} = 30 mA; T _A = 25°C	V _{IND(sat)}	–	560	800	mV
Indicator Output Leakage Current V _{OH(IND)} = 40 V	I _{IND(leak)}	–	25	200	nA
Output Comparator Threshold Voltage (Note 3)	V _{th(OC)}	2.33	2.5	2.63	V
Propagation Delay Time (V _{CC} = 15 V; T _A = 25°C) Input to Drive Output or Indicator Output 100 mV Overdrive, C _{DLY} = 0 μF	t _{PLH(IN/OUT)}	–	1.7	–	μs
Input to Delay 2.5 V Overdrive (0 V to 5.0 V Step)	t _{PLH(IN/DLY)}	–	700	–	ns

NOTES: 2. T_{low} to T_{high} = 0° to +70°C

3. The V_{th(OC)} limits are approximately the V_{Sense} limits over the applicable temperature range.

Figure 1. Hysteresis Current versus Hysteresis Activation Voltage

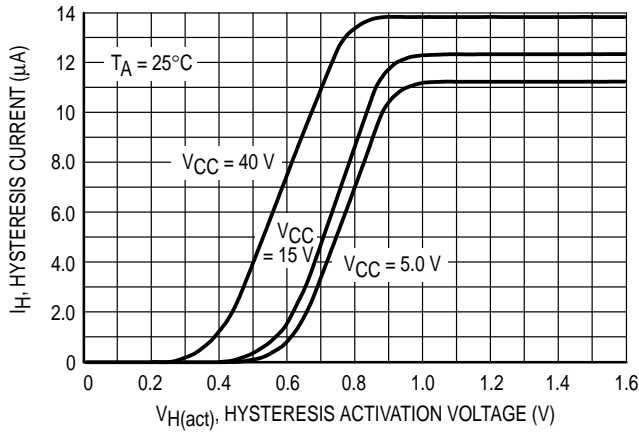

Figure 2. Hysteresis Activation Voltage versus Temperature

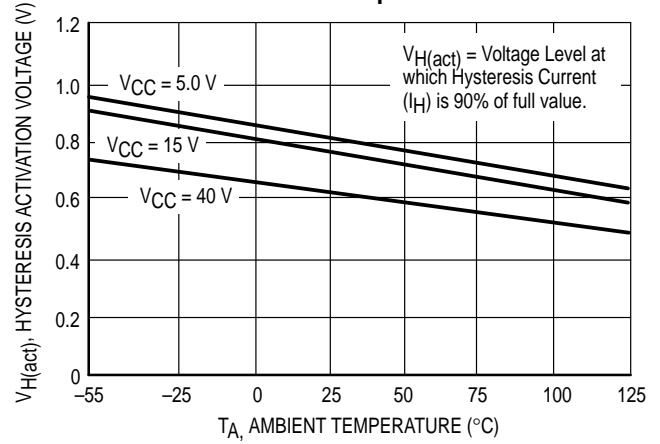

Figure 3. Hysteresis Current versus Temperature

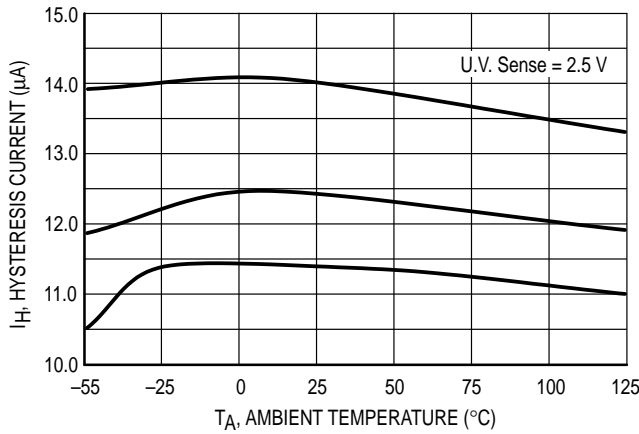

Figure 4. Sense Trip Voltage Change versus Temperature

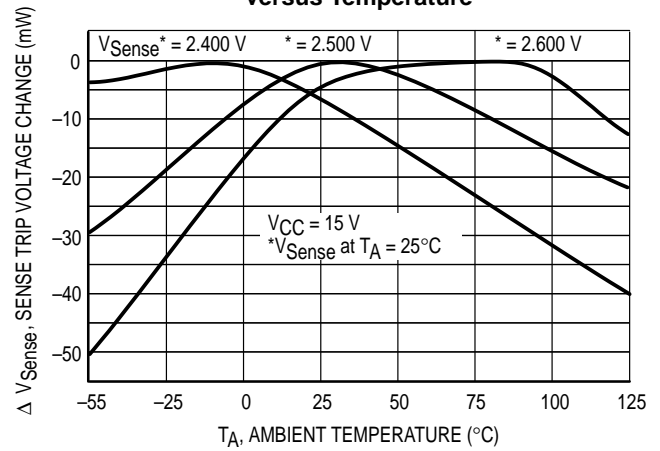

Figure 5. Output Delay Time versus Delay Capacitance

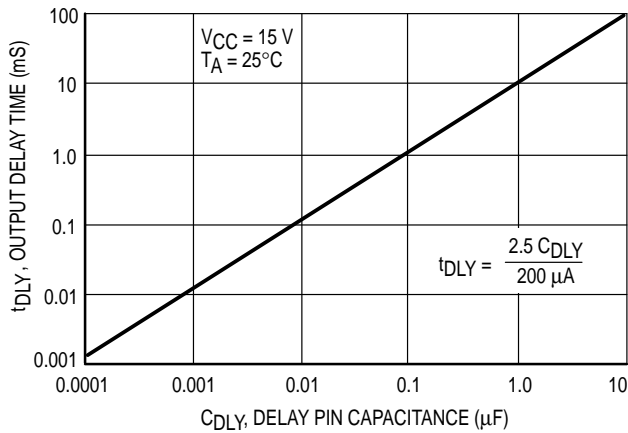

Figure 6. Delay Pin Source Current versus Temperature

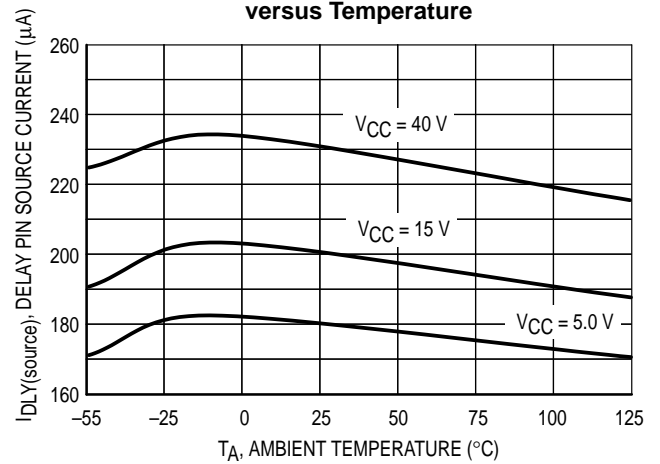

Figure 7. Drive Output Saturation Voltage versus Output Peak Current

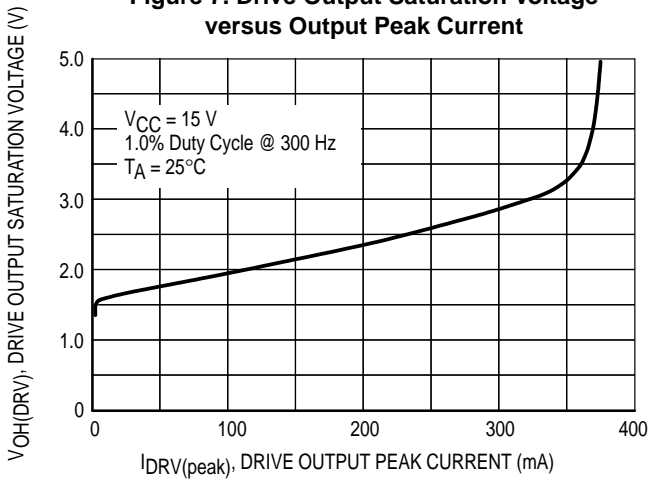

Figure 8. Indicator Output Saturation Voltage versus Output Sink Current

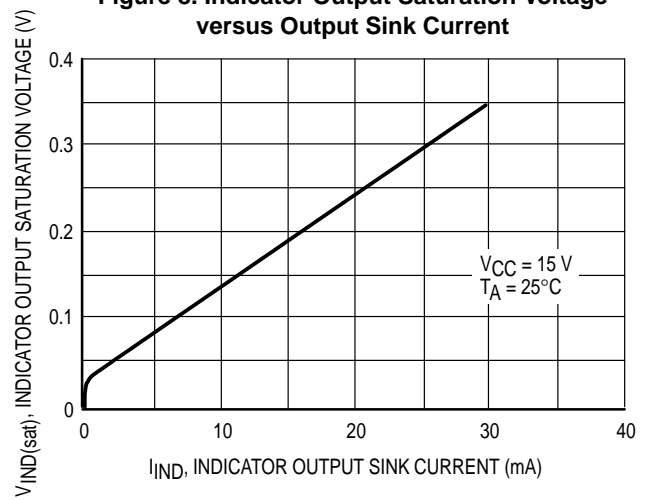

Figure 9. Drive Output Saturation Voltage versus Temperature

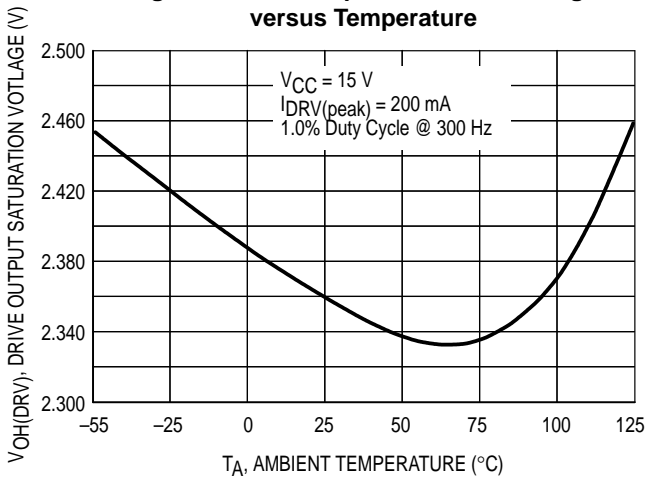
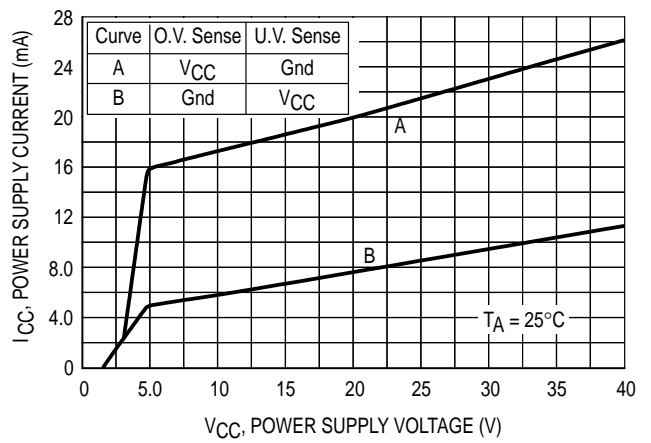

Figure 10. Power Supply Current versus Voltage



MC3425

APPLICATIONS INFORMATION

Figure 11. Overvoltage Protection and Undervoltage Fault Indication with Programmable Delay

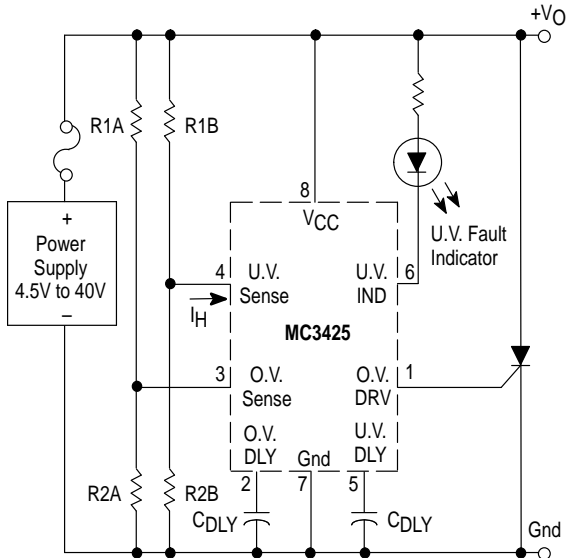

$$U.V. \text{ Hysteresis} = I_H \left(\frac{R1B R2B}{R1B + R2B} \right), V_{O(trip)} - 2.5V \left(1 + \frac{R1A}{R2A} \right)$$

$$t_{DLY} = 12500 C_{DLY}$$

Figure 12. Overvoltage Protection of 5.0 V Supply with Line Loss Detector

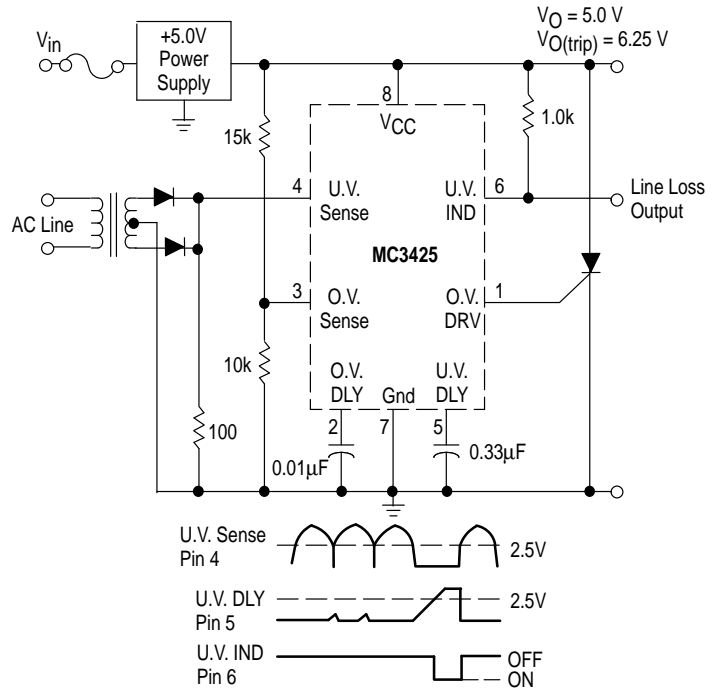

Figure 13. Overvoltage Audio Alarm Circuit

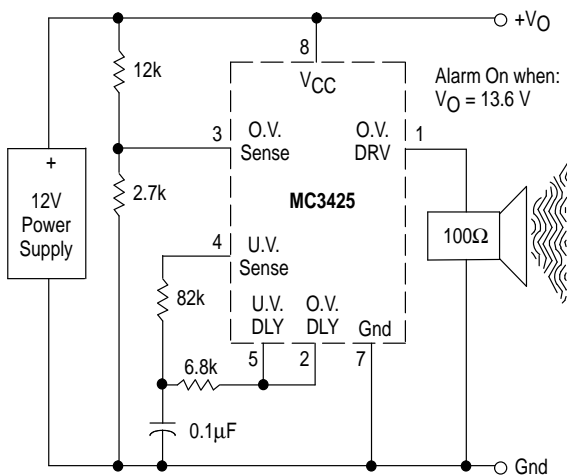
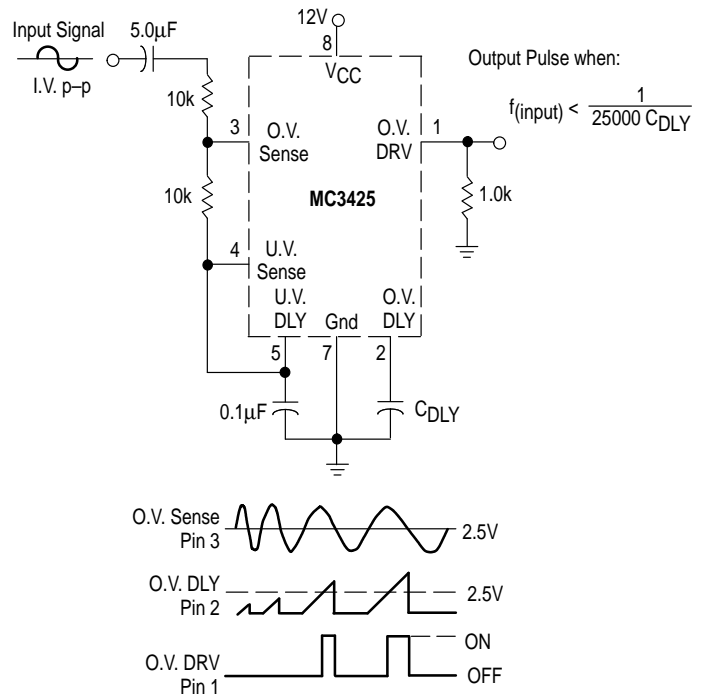

Figure 14. Programmable Frequency Switch



MC3425

CIRCUIT DESCRIPTION

The MC3425 is a power supply supervisory circuit containing all the necessary functions required to monitor over and undervoltage fault conditions. The block diagram is shown below in Figure 15. The Overvoltage (O.V.) and Undervoltage (U.V.) Input Comparators are both referenced to an internal 2.5 V regulator. The U.V. Input Comparator has a feedback activated 12.5 μ A current sink (I_H) which is used for programming the input hysteresis voltage (V_H). The source resistance feeding this input (R_H) determines the amount of hysteresis voltage by $V_H = I_H R_H = 12.5 \times 10^{-6} R_H$.

Separate Delay pins (O.V. DLY, U.V. DLY.) are provided for each channel to independently delay the Drive and Indicator outputs, thus providing greater input noise immunity. The two Delay pins are essentially the outputs of the respective input comparators, and provide a constant current source, $I_{DLY(source)}$, of typically 200 μ A when the noninverting input voltage is greater than the inverting input level. A capacitor connected from these Delay pins to ground, will establish a predictable delay time (t_{DLY}) for the Drive and Indicator outputs. The Delay pins are internally connected to the noninverting inputs of the O.V. and U.V. Output Comparators, which are referenced to the internal 2.5 V regulator. Therefore, delay time (t_{DLY}) is based on the constant current

source, $I_{DLY(source)}$, charging the external delay capacitor (C_{DLY}) to 2.5 V.

$$t_{DLY} = \frac{V_{ref} C_{DLY}}{I_{DLY(source)}} = \frac{2.5 C_{DLY}}{200 \mu A} = 12500 C_{DLY}$$

Figure 5 provides C_{DLY} values for a wide range of time delays. The Delay pins are pulled low when the respective input comparator's noninverting input is less than the inverting input. The sink current, $I_{DLY(sink)}$, capability of the Delay pins is ≥ 1.8 mA and is much greater than the typical 200 μ A source current, thus enabling a relatively fast delay capacitor discharge time.

The Overvoltage Drive Output is a current-limited emitter-follower capable of sourcing 300 mA at a turn-on slew rate at 2.0 A/ μ s, ideal for driving "Crowbar" SCR's. The Undervoltage Indicator Output is an open-collector, NPN transistor, capable of sinking 30 mA to provide sufficient drive for LED's, small relays or shut-down circuitry. These current capabilities apply to both channels operating simultaneously, providing device power dissipation limits are not exceeded.

The MC3425 has an internal 2.5 V bandgap reference regulator with an accuracy of $\pm 4.0\%$ for the basic device.

Figure 15. Representative Block Diagram

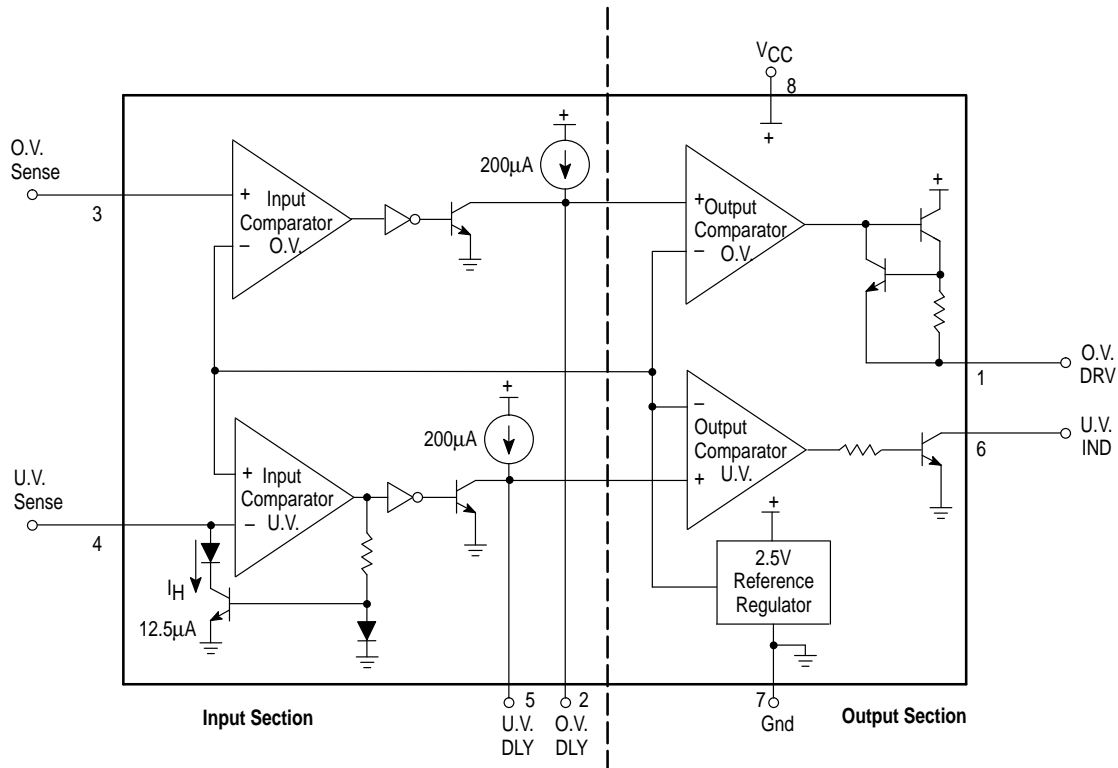

Note: All voltages and currents are nominal.

MC3425

CROWBAR SCR CONSIDERATIONS

Referring to Figure 16, it can be seen that the crowbar SCR, when activated, is subject to a large current surge from the output capacitance, C_{out} . This capacitance consists of the power supply output capacitors, the load's decoupling capacitors, and in the case of Figure 16A, the supply's input filter capacitors. This surge current is illustrated in Figure 17, and can cause SCR failure or degradation by any one of three mechanisms: di/dt , absolute peak surge, or I^2t . The interrelationship of these failure methods and the breadth of the applications make specification of the SCR by the semiconductor manufacturer difficult and expensive. Therefore, the designer must empirically determine the SCR and circuit elements which result in reliable and effective OVP operation. However, an understanding of the factors which influence the SCR's di/dt and surge capabilities simplifies this task.

1. di/dt

As the gate region of the SCR is driven on, its area of conduction takes a finite amount of time to grow, starting as a very small region and gradually spreading. Since the anode

current flows through this turned-on gate region, very high current densities can occur in the gate region if high anode currents appear quickly (di/dt). This can result in immediate destruction of the SCR or gradual degradation of its forward blocking voltage capabilities – depending on the severity of the occasion.

The value of di/dt that an SCR can safely handle is influenced by its construction and the characteristics of the gate drive signal. A center-gate-fire SCR has more di/dt capability than a corner-gate-fire type, and heavily overdriving (3 to 5 times I_{GT}) the SCR gate with a fast $< 1.0 \mu s$ rise time signal will maximize its di/dt capability. A typical maximum number in phase control SCRs of less than 50 A(RMS) rating might be 200 A/ μs , assuming a gate current of five times I_{GT} and $< 1.0 \mu s$ rise time. If having done this, a di/dt problem is seen to still exist, the designer can also decrease the di/dt of the current waveform by adding inductance in series with the SCR, as shown in Figure 18. Of course, this reduces the circuit's ability to rapidly reduce the dc bus voltage and a tradeoff must be made between speedy voltage reduction and di/dt .

Figure 16. Typical Crowbar Circuit Configurations

(A) SCR Across Input of Regulator

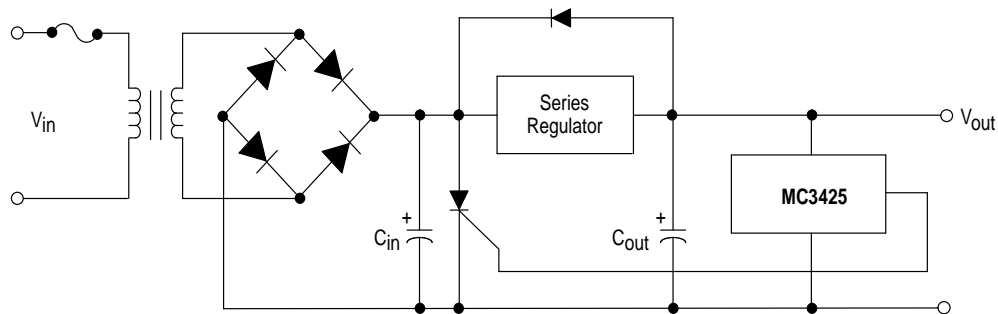

(B) SCR Across Output of Regulator

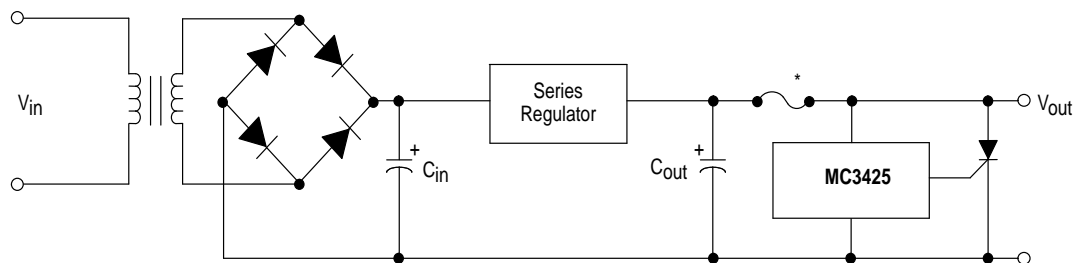

*Needed if supply is not current limited.

Figure 17. Crowbar SCR Surge Current Waveform

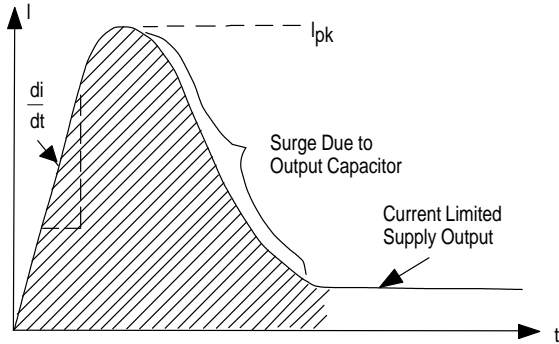

2. Surge Current

If the peak current and/or the duration of the surge is excessive, immediate destruction due to device overheating will result. The surge capability of the SCR is directly proportional to its die area. If the surge current cannot be reduced (by adding series resistance – see Figure 18) to a safe level which is consistent with the system’s requirements for speedy bus voltage reduction, the designer must use a higher current SCR. This may result in the average current capability of the SCR exceeding the steady state current requirements imposed by the DC power supply.

Figure 18. Circuit Elements Affecting SCR Surge & di/dt

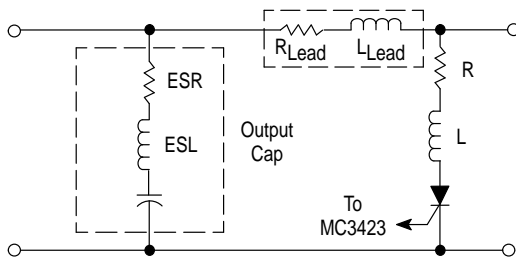

R & L EMPIRICALLY DETERMINED!

UNDERVOLTAGE SENSING

An undervoltage sense circuit with hysteresis may be designed, as shown in Figure 11, using the following equations:

$$R1 = \frac{V_{CCU} - V_{CC1}}{12.5 \mu A}$$

$$R2 = \frac{2.5 R1}{V_{CC1} - 2.5}$$

where: V_{CCU} is the designed upper trip point (output indicator goes off)
 V_{CC1} is the lower trip point (output indicator goes on)

A WORD ABOUT FUSING

Before leaving the subject of the crowbar SCR, a few words about fuse protection are in order. Referring back to Figure 16A, it will be seen that a fuse is necessary if the power supply to be protected is not output current limited. This fuse is not meant to prevent SCR failure but rather to prevent a fire!

In order to protect the SCR, the fuse would have to possess an I^2t rating less than that of the SCR and yet have a high enough continuous current rating to survive normal supply output currents. In addition, it must be capable of successfully clearing the high short circuit currents from the supply. Such a fuse as this is quite expensive, and may not even be available.

The usual design compromise then is to use a garden variety fuse (3AG or 3AB style) which cannot be relied on to blow before the thyristor does, and trust that if the SCR does fail, it will fail short circuit. In the majority of the designs, this will be the case, though this is difficult to guarantee. Of course, a sufficiently high surge will cause an open. These comments also apply to the fuse in Figure 16B.

CROWBAR SCR SELECTION GUIDE

As an aid in selecting an SCR for crowbar use, the following selection guide is presented.

Device	I_{RMS}	I_{TSM}
MCR310 Series	10 A	100 A
MCR16 Series	16 A	150 A
MCR25 Series	25 A	300 A
2N6501 Series	25 A	300 A
MCR69 Series	25 A	750 A
MCR264 Series	40 A	400 A
MCR265 Series	55 A	550 A

MC3425

OUTLINE DIMENSIONS

P1 SUFFIX
PLASTIC PACKAGE
CASE 626-05
ISSUE K

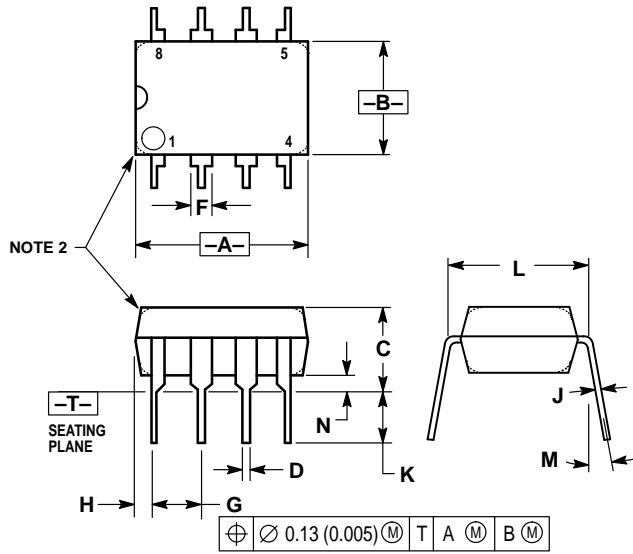

NOTES:

1. DIMENSION L TO CENTER OF LEAD WHEN FORMED PARALLEL.
2. PACKAGE CONTOUR OPTIONAL (ROUND OR SQUARE CORNERS).
3. DIMENSIONING AND TOLERANCING PER ANSI Y14.5M, 1982.

MILLIMETERS		INCHES		
DIM	MIN	MAX	MIN	MAX
A	9.40	10.16	0.370	0.400
B	6.10	6.60	0.240	0.260
C	3.94	4.45	0.155	0.175
D	0.38	0.51	0.015	0.020
F	1.02	1.78	0.040	0.070
G	2.54 BSC		0.100 BSC	
H	0.76	1.27	0.030	0.050
J	0.20	0.30	0.008	0.012
K	2.92	3.43	0.115	0.135
L	7.62 BSC		0.300 BSC	
M	10°		10°	
N	0.76	1.01	0.030	0.040

MC3425
NOTES

MC3425
NOTES

Motorola reserves the right to make changes without further notice to any products herein. Motorola makes no warranty, representation or guarantee regarding the suitability of its products for any particular purpose, nor does Motorola assume any liability arising out of the application or use of any product or circuit, and specifically disclaims any and all liability, including without limitation consequential or incidental damages. "Typical" parameters which may be provided in Motorola data sheets and/or specifications can and do vary in different applications and actual performance may vary over time. All operating parameters, including "Typicals" must be validated for each customer application by customer's technical experts. Motorola does not convey any license under its patent rights nor the rights of others. Motorola products are not designed, intended, or authorized for use as components in systems intended for surgical implant into the body, or other applications intended to support or sustain life, or for any other application in which the failure of the Motorola product could create a situation where personal injury or death may occur. Should Buyer purchase or use Motorola products for any such unintended or unauthorized application, Buyer shall indemnify and hold Motorola and its officers, employees, subsidiaries, affiliates, and distributors harmless against all claims, costs, damages, and expenses, and reasonable attorney fees arising out of, directly or indirectly, any claim of personal injury or death associated with such unintended or unauthorized use, even if such claim alleges that Motorola was negligent regarding the design or manufacture of the part. Motorola and  registered trademarks of Motorola, Inc. Motorola, Inc. is an Equal Opportunity/Affirmative Action Employer.

How to reach us:

USA/EUROPE/Locations Not Listed: Motorola Literature Distribution;
P.O. Box 20912; Phoenix, Arizona 85036. 1-800-441-2447 or 602-303-5454

MFAX: RMFAX0@email.sps.mot.com – TOUCHTONE 602-244-6609
INTERNET: <http://Design-NET.com>

JAPAN: Nippon Motorola Ltd.; Tatsumi-SPD-JLDC, 6F Seibu-Butsuryu-Center,
3-14-2 Tatsumi Koto-Ku, Tokyo 135, Japan. 03-81-3521-8315

ASIA/PACIFIC: Motorola Semiconductors H.K. Ltd.; 8B Tai Ping Industrial Park,
51 Ting Kok Road, Tai Po, N.T., Hong Kong. 852-26629298

